

Beam Sensors

Gent by Honeywell's S-Quad Beam Sensors provides an enhanced solution for linear beam detection for applications where point detection is either not practical or economic.

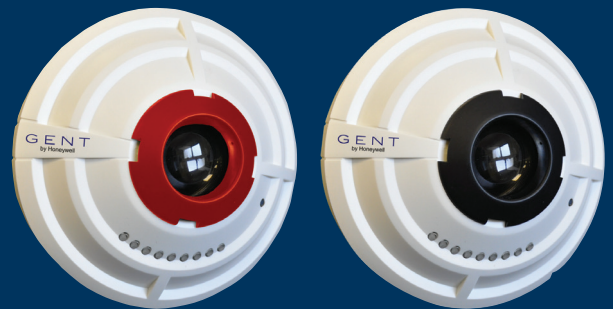

Description

Vigilon's loop powered technology allows up to 16 beam pairs to be connected to the same loop circuit, each covering a distance of up to 100m without the need for an external Power Supply Unit, wiring or interfacing.

Compatible with the full range of Vigilon and Nano control panels the S-Quad beam uses the panel software to ensure a fast response to fire while offering software filters to reduce the number of unwanted alarms.

Key Features

- S-Quad Beam pairs are loop powered supporting 16 pairs per loop
- Each beam can be set to one of 6 sensitivity states to provide a best fit for individual applications
- The beam provides increased resilience to interference from the sun and other light sources
- Remote key switch provides test facility at ground level without the need to gain access to beams mounted in high areas
- The beam incorporates an LED array to indicate signal strength allowing accurate alignment during one person commissioning
- Optimum sensitivity is maintained by automatic gain setting triggered at the beam during alignment
- The optical lens design is intended to minimise build up of dust to reduce the maintenance and cleaning required
- The S-Quad beam is compatible with early versions of the Vigilon Beam using the S-Quad programming base avoiding the need to upgrade to latest control software

Schematic of the Beam Sensor

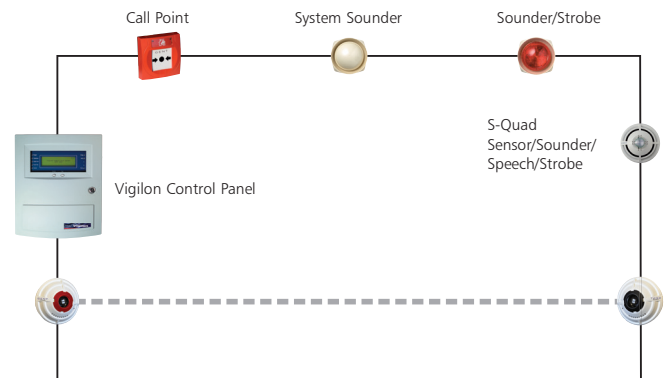

Beam Transmitter

- Loop Powered (16 per loop)
- LED array to assist alignment
- Auto gain adjustment allowing 1 man commissioning



Beam Receiver

- Loop Powered (16 per loop)
- 100m beam transmission
- Improved immunity to EMC & dust build up on the lens

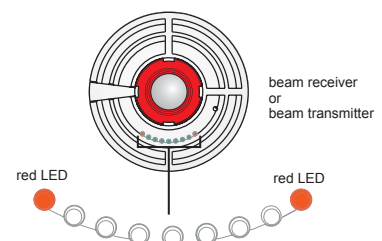

SPECIFICATION

Standards	Certified EN54:Part12 and EN54:Part17
LPCB Number	042bh
Approved State(s)	0,1,2 and 3
Ambient Temperature	-10°C to +60°C
Storage Temperature	-15°C to +65°C
Protection Class	IP30 (IP20 when mounted on bracket)
Housing	ABS Plastic
Weight	Transmitter or receiver 105g
	Angle bracket and base 620g
	Parallel bracket and base 600g
	Light shield 14g
Dimension (HxWxD)	Transmitter or receiver: 117 x 117 x 54(mm)
	Angle Bracket with base: 145 x 106 x 130(mm)
	Parallel bracket: 152 x 152 x 27(mm)
Operating Voltage	35-41V
Colour	RAL 9010
Emissions	BS EN50081-1:1992 part 1 residential, commercial and light industry Class B limits
Immunity	BS EN50130-4 1996:part 4 Alarm systems
Transmission Path	2 – 100m

GENT

by Honeywell

Accessories

S-Quad Beam is supported by a comprehensive range of accessories and mounting brackets.

- Angle Bracket for difficult applications allowing wide angle adjustment up to +/- 30°
- Parallel bracket for standard applications adjustable to +/- 15°
- Light shield is available for installation in areas where direct sunlight cannot be avoided
- Obscuration test kit to assist with commissioning

Dimensions

Beam Transmitter (with Angle Bracket*)

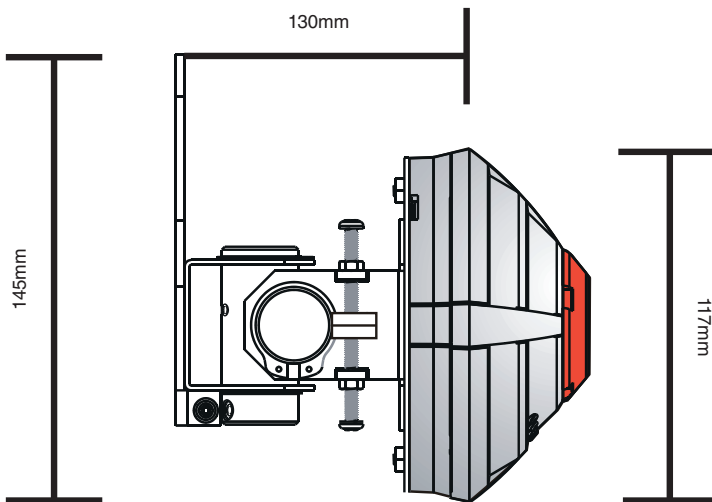

Beam Receiver (with Parallel Bracket*)

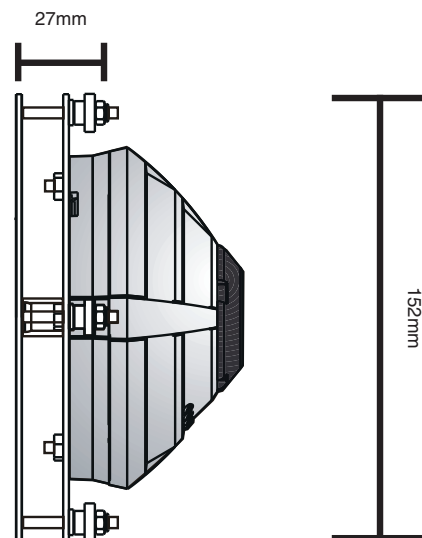

* Angle and Parallel brackets not supplied as standard

DESCRIPTION

ORDER CODES

Beam Pair	S4-34740
Beam Sensor Transmitter	S4-34741
Beam Sensor Receiver	S4-34742
Angle Bracket	S4-34741-01
Parallel Bracket	S4-34741-03
Light Shield	S4-34741-99
Obscuration Test Card Set	S4-34741-50

Gent By Honeywell
140 Waterside Road,
Hamilton Industrial Park,
Leicester, LE5 1TN.

t 0116 246 2042
e gentenquiry@honeywell.com
www.gent.co.uk



Literature ref: GEN097